



# GL20N02A4

## GL Silicon N-Channel Power MOSFET

### General Description:

The GL20N02A4 uses advanced trench technology and design to provide excellent  $R_{DS(ON)}$  with low gate charge. It can be used in a wide variety of applications. The package form is TO-252, which accords with the RoHS standard.

$V_{DSS}$	20	V
$I_D$	20	A
$P_D$	32.5	W
$R_{DS(ON)type}$	12	m $\Omega$

### Features:

- $R_{DS(ON)} < 15m\Omega @ V_{GS}=10V$
- High density cell design for ultra low  $R_{dson}$
- Fully characterized avalanche voltage and current
- Excellent package for good heat dissipation

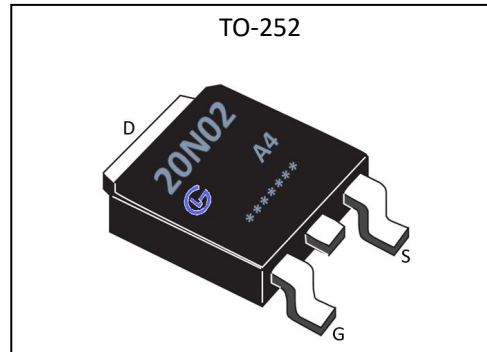

### Applications:

- Power switching application
- Hard switched and high frequency circuits
- Uninterruptible power supply

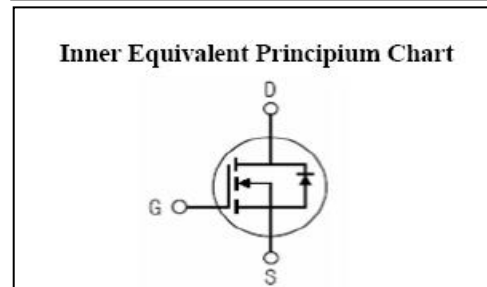

### Absolute (Tc= 25°C unless otherwise specified):

Symbol	Parameter	Rating	Units
$V_{DSS}$	Drain-to-Source Voltage	20	V
$I_D$	Continuous Drain Current	20	A
$I_{DM}$	Pulsed Drain Current	80	A
$V_{GS}$	Gate-to-Source Voltage	$\pm 12$	V
$P_D$	Power Dissipation	32.5	W
$T_J, T_{stg}$	Operating Junction and Storage Temperature Range	150, -55 to 150	$^{\circ}C$



# GL20N02A4

## GL Silicon N-Channel Power MOSFET

Electrical Characteristics (Tc= 25°C unless otherwise specified) :

OFF Characteristics						
Symbol	Parameter	Test Conditions	Rating			Units
			Min.	Typ.	Max.	
V <sub>DSS</sub>	Drain to Source Breakdown Voltage	V <sub>GS</sub> =0V, I <sub>D</sub> =250μA	20	--	--	V
I <sub>DSS</sub>	Drain to Source Leakage Current	V <sub>DS</sub> =20V, V <sub>GS</sub> = 0V, T <sub>a</sub> =25°C	--	--	1.0	μA
I <sub>GSS(F)</sub>	Gate to Source Forward Leakage	V <sub>GS</sub> = +12V	--	--	0.1	μA
I <sub>GSS(R)</sub>	Gate to Source Reverse Leakage	V <sub>GS</sub> = -12V	--	--	-0.1	μA

ON Characteristics <sup>a3</sup>						
Symbol	Parameter	Test Conditions	Rating			Units
			Min.	Typ.	Max.	
R <sub>DS(ON)</sub>	Drain-to-Source On-Resistance	V <sub>GS</sub> =10V, I <sub>D</sub> =10A	--	12	15	mΩ
R <sub>DS(ON)</sub>	Drain-to-Source On-Resistance	V <sub>GS</sub> =4.5V, I <sub>D</sub> =6A	--	13.5	18	mΩ
V <sub>GS(TH)</sub>	Gate Threshold Voltage	V <sub>DS</sub> =V <sub>GS</sub> , I <sub>D</sub> =250μA	0.5	--	1.0	V
Pulse width tp ≤ 380μs, δ ≤ 2%						

Dynamic Characteristics <sup>a4</sup>						
Symbol	Parameter	Test Conditions	Rating			Units
			Min.	Typ.	Max.	
g <sub>fs</sub>	Forward Transconductance	V <sub>DS</sub> =10V, I <sub>D</sub> =5A	6	--	--	S
C <sub>iss</sub>	Input Capacitance	V <sub>GS</sub> =0V, V <sub>DS</sub> =10V f=1.0MHz	--	850	--	pF
C <sub>oss</sub>	Output Capacitance		--	100	--	
C <sub>rss</sub>	Reverse Transfer Capacitance		--	55	--	

Resistive Switching Characteristics <sup>a4</sup>						
Symbol	Parameter	Test Conditions	Rating			Units
			Min.	Typ.	Max.	
t <sub>d(ON)</sub>	Turn-on Delay Time	V <sub>DD</sub> =10V, I <sub>D</sub> =10A V <sub>GS</sub> =5V, R <sub>G</sub> =1Ω	--	10	--	ns
t <sub>r</sub>	Rise Time		--	20	--	
t <sub>d(OFF)</sub>	Turn-Off Delay Time		--	32	--	
t <sub>f</sub>	Fall Time		--	12	--	
Q <sub>g</sub>	Total Gate Charge	V <sub>DD</sub> =10V, I <sub>D</sub> =4A V <sub>GS</sub> =4.5V	--	9	--	nC
Q <sub>gs</sub>	Gate to Source Charge		--	2	--	
Q <sub>gd</sub>	Gate to Drain ( "Miller" )Charge		--	2.8	--	



# GL20N02A4

## GL Silicon N-Channel Power MOSFET

Source-Drain Diode Characteristics						
Symbol	Parameter	Test Conditions	Rating			Units
			Min.	Typ.	Max.	
$I_S$	Continuous Source Current <sup>a2</sup> (Body Diode)		--	--	20	A
$V_{SD}$	Diode Forward Voltage <sup>a3</sup>	$I_S=20A, V_{GS}=0V$	--	--	1.5	V

Symbol	Parameter	Typ.	Units
$R_{\theta JC}$	Junction-to-Case <sup>a2</sup>	3.846	°C/W

<sup>a1</sup>: Repetitive Rating: Pulse width limited by maximum junction temperature.

<sup>a2</sup>: Surface Mounted on FR4 Board,  $t \leq 10\text{sec}$ .

<sup>a3</sup>: Pulse Test: Pulse Width  $\leq 300\mu\text{s}$ , Duty Cycle  $\leq 2\%$ .

<sup>a4</sup>: Guaranteed by design, not subject to production

### Characteristics Curve:

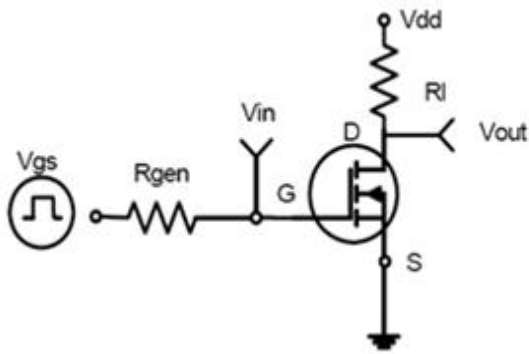

Figure 1: Switching Test Circuit

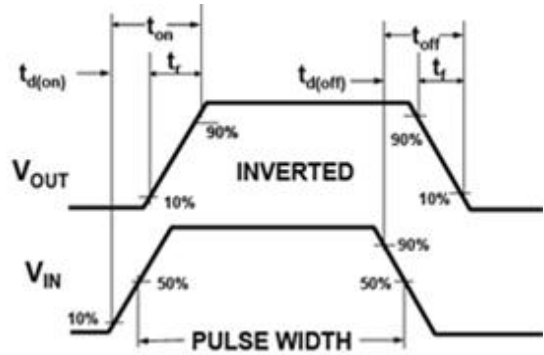

Figure 2: Switching Waveforms

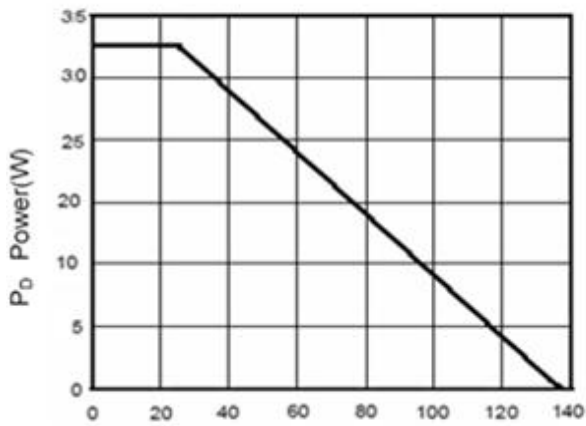

Figure 3 Power Dissipation

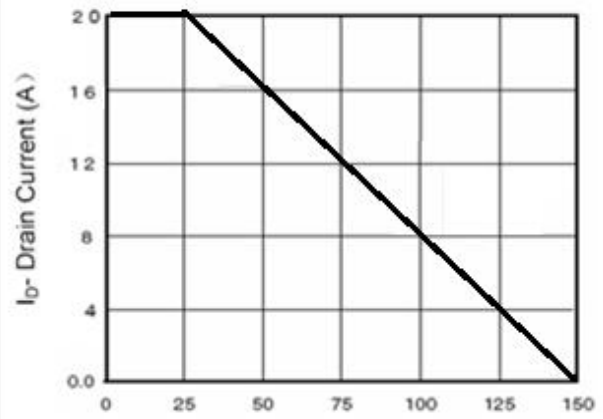

Figure 4 Drain Current

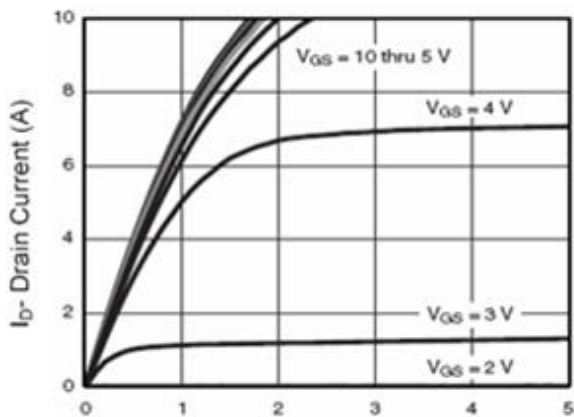

Figure 5 Output Characteristics

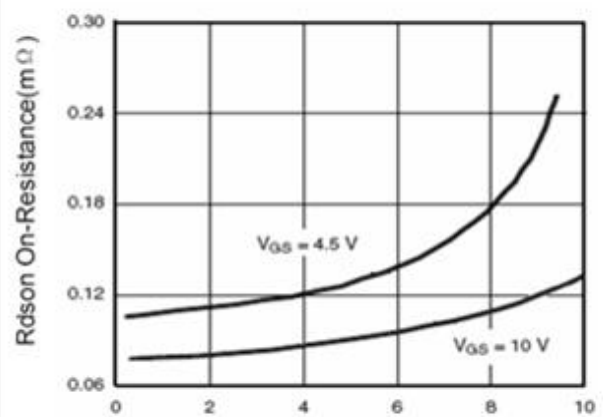

Figure 6 Drain-Source On-Resistance



# GL20N02A4

## GL Silicon N-Channel Power MOSFET

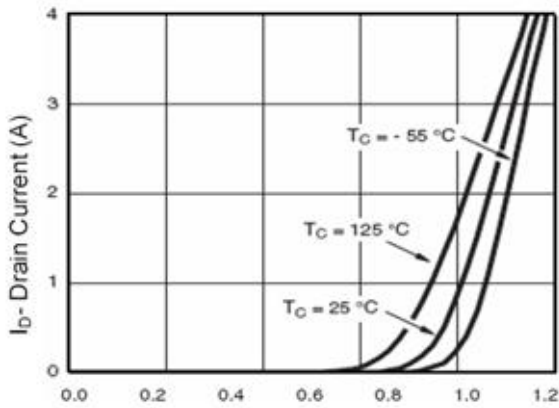

Figure 7 Transfer Characteristics

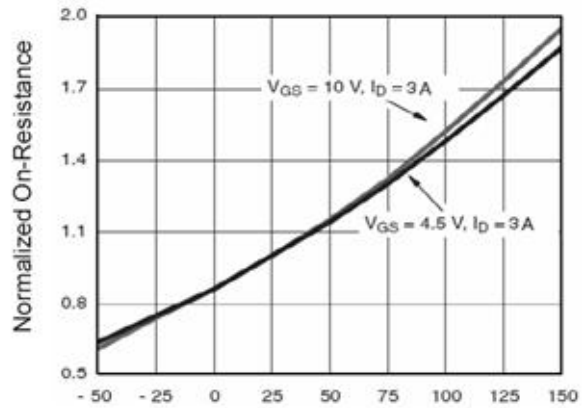

Figure 8 Drain-Source On-Resistance

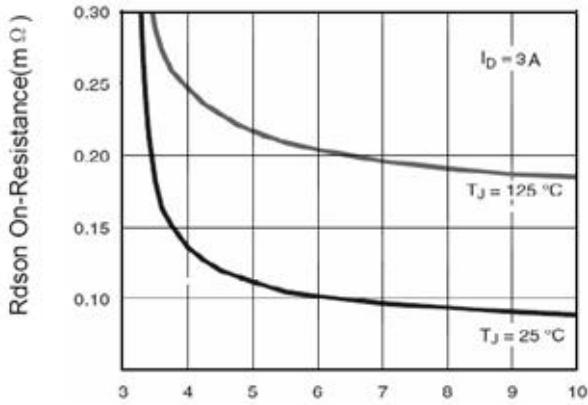

Figure 9 Rdson vs Vgs

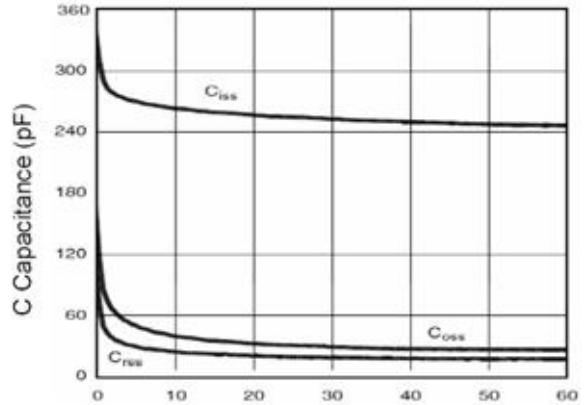

Figure 10 Capacitance vs Vds

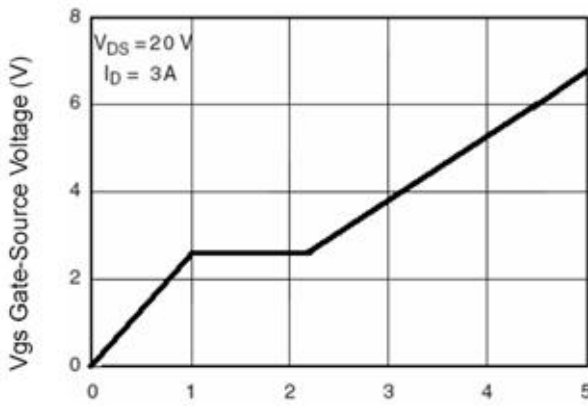

Figure 11 Gate Charge

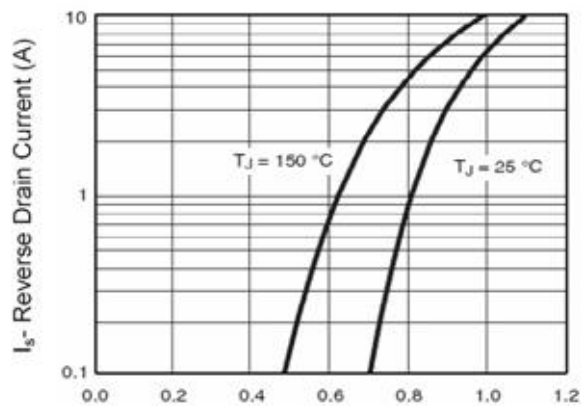

Figure 12 Source-Drain Diode Forward