



GL3404

GL Silicon N-Channel Power MOSFET

General Description:

The GL3404 uses advanced trench technology and design to provide excellent RDS(ON) with low gate charge. It can be used in a wide variety of applications. The package form is SOT-23, which accords with the RoHS standard.

Features:

- Fast Switching
- Low Gate Charge and Rds(on)
- Low Reverse transfer capacitances
- 100% Single Pulse avalanche energy Test

Applications:

- PWM applications
- Load switch
- Power management

V_{DSS}	30	V
I_D	5.8	A
P_D	1.4	W
$R_{DS(ON),TYP.}$	25	mΩ

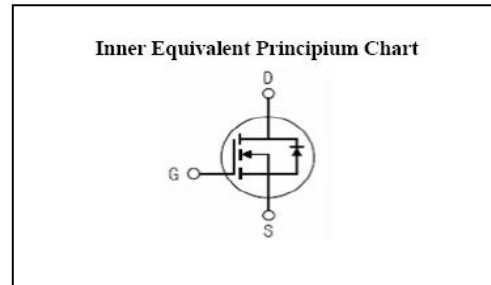
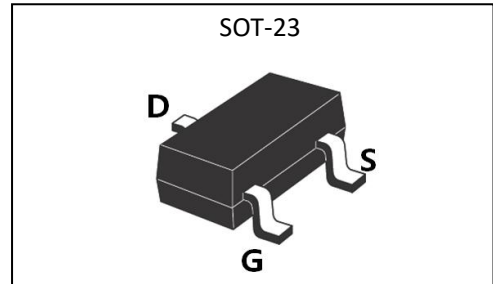

Absolute (Tc= 25°C unless otherwise specified):

Symbol	Parameter	Rating	Units
V_{DSS}	Drain-to-Source Voltage	30	V
I_D	Continuous Drain Current	5.8	A
	Continuous Drain Current $T_C = 70\text{ °C}$	4.5	A
I_{DM}^{a1}	Pulsed Drain Current	20	A
V_{GS}	Gate-to-Source Voltage	± 20	V
dv/dt^{a3}	Peak Diode Recovery dv/dt	5.0	V/ns
P_D	Power Dissipation	1.4	W
T_J, T_{stg}	Operating Junction and Storage Temperature Range	150, -55 to 150	°C
T_L	Maximum Temperature for Soldering	300	°C



GL3404

GL Silicon N-Channel Power MOSFET

Electrical Characteristics (T_c= 25°C unless otherwise specified) :

OFF Characteristics						
Symbol	Parameter	Test Conditions	Rating			Units
			Min.	Typ.	Max.	
V _{DSS}	Drain to Source Breakdown Voltage	V _{GS} =0V, I _D =-250μA	30	--	--	V
ΔBV _{DSS} /ΔT _J	Bvdss Temperature Coefficient	I _D =-250uA, Reference 25°C	--	0.1	--	V/°C
I _{DSS}	Drain to Source Leakage Current	V _{DS} =30, V _{GS} = 0V, T _a = 25°C	--	--	1	μA
		V _{DS} =24V, V _{GS} = 0V, T _a =125°C	--	--	250	
I _{GSS(F)}	Gate to Source Forward Leakage	V _{GS} = +20V	--	--	1	μA
I _{GSS(R)}	Gate to Source Reverse Leakage	V _{GS} = -20V	--	--	-1	μA

ON Characteristics						
Symbol	Parameter	Test Conditions	Rating			Units
			Min.	Typ.	Max.	
R _{DS(ON)}	Drain-to-Source On-Resistance	V _{GS} =10V, I _D =5.0A	--	25	31	mΩ
R _{DS(ON)}	Drain-to-Source On-Resistance	V _{GS} =4.5V, I _D =4.0A	--	36	43	mΩ
V _{GS(TH)}	Gate Threshold Voltage	V _{DS} =V _{GS} , I _D =250μA	0.7	0.9	1.4	V
Pulse width tp ≤ 380μs, δ ≤ 2%						

Dynamic Characteristics						
Symbol	Parameter	Test Conditions	Rating			Units
			Min.	Typ.	Max.	
g _{fs}	Forward Transconductance	V _{DS} =5V, I _D =5.0A	--	15	--	S
C _{iss}	Input Capacitance	V _{GS} =0V, V _{DS} =15V f=1.0MHz	--	250	--	pF
C _{oss}	Output Capacitance		--	45	--	
C _{rss}	Reverse Transfer Capacitance		--	35	--	

Resistive Switching Characteristics						
Symbol	Parameter	Test Conditions	Rating			Units
			Min.	Typ.	Max.	
t _{d(ON)}	Turn-on Delay Time	I _D =1.0A, V _{DD} =15V V _{GS} =10V, R _G =3.0Ω	--	4.5	--	ns
t _r	Rise Time		--	2.5	--	
t _{d(OFF)}	Turn-Off Delay Time		--	15	--	
t _f	Fall Time		--	3.5	--	
Q _g	Total Gate Charge	I _D =5.0A, V _{DD} =15V V _{GS} =10V	--	5.2	--	nC
Q _{gs}	Gate to Source Charge		--	0.9	--	
Q _{gd}	Gate to Drain ("Miller") Charge		--	1.3	--	

Source-Drain Diode Characteristics

Symbol	Parameter	Test Conditions	Rating			Units
			Min.	Typ.	Max.	
I_S	Continuous Source Current (Body Diode)		--	--	5.0	A
I_{SM}	Maximum Pulsed Current (Body Diode)		--	--	20	A
V_{SD}	Diode Forward Voltage	$I_S = 5.0A, V_{GS} = 0V$	--	--	1.5	V
t_{rr}	Reverse Recovery Time	$I_S = 5.0A, T_j = 25^\circ C$	--	44	--	ns
Q_{rr}	Reverse Recovery Charge	$di_F/dt = 100A/us, V_{GS} = 0V$	--	110	--	nC

Pulse width $t_p \leq 380\mu s, \delta \leq 2\%$

Symbol	Parameter	Typ.	Units
$R_{\theta JA}$	Junction-to-Ambient	90	$^\circ C/W$

^{a1}: Repetitive rating; pulse width limited by maximum junction temperature

^{a3}: $I_{SD} = 5.0A, di/dt \leq 100A/us, V_{DD} \leq BV_{DS}, \text{Start } T_j = 25^\circ C$

Typical Electrical and Thermal Characteristics

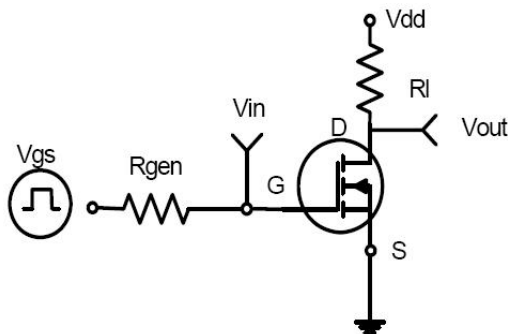

Figure 1: Switching Test Circuit

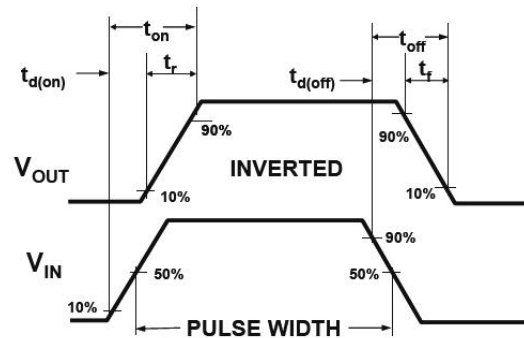

Figure 2: Switching Waveforms



GL3404

GL Silicon N-Channel Power MOSFET

Characteristics Curve:

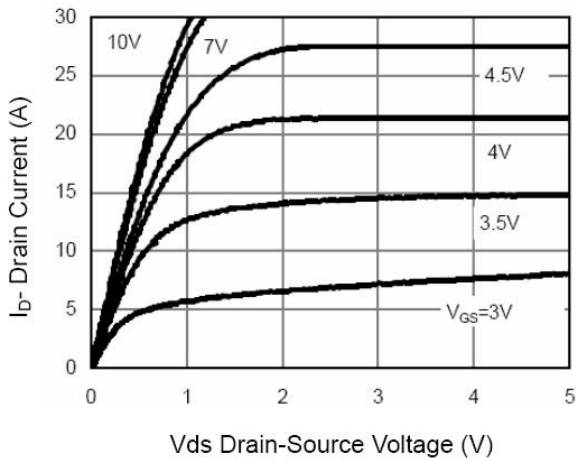

Figure 3 Output Characteristics

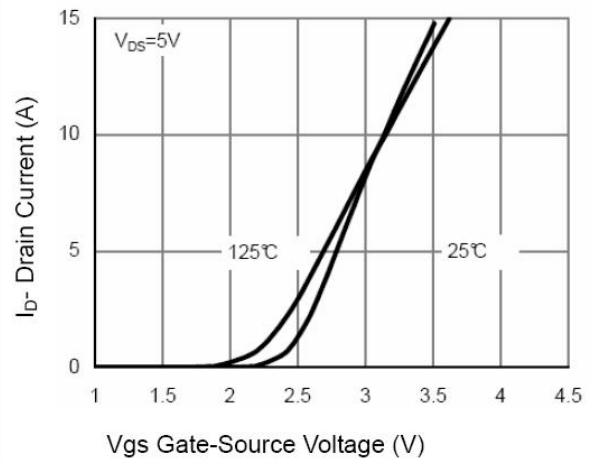

Figure 4 Transfer Characteristics

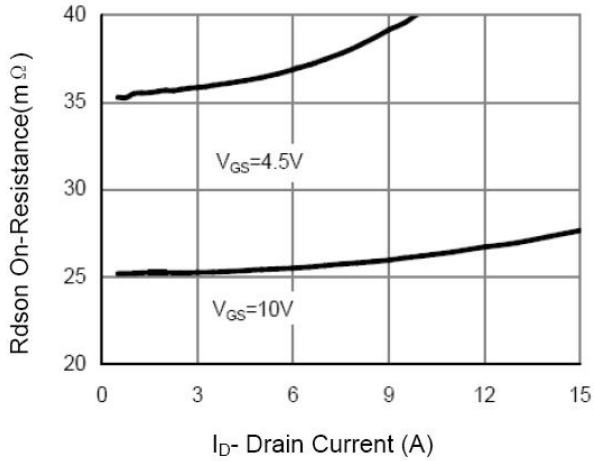

Figure 5 Drain-Source On-Resistance

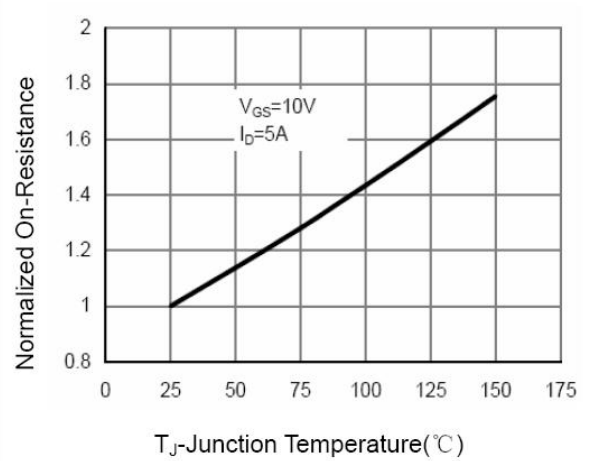

Figure 6 Drain-Source On-Resistance



GL3404

GL Silicon N-Channel Power MOSFET

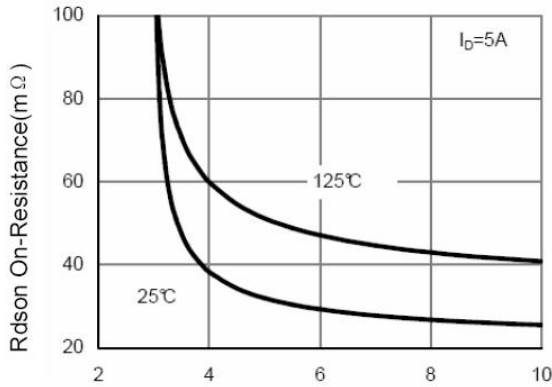

Figure 7 Rdson vs Vgs

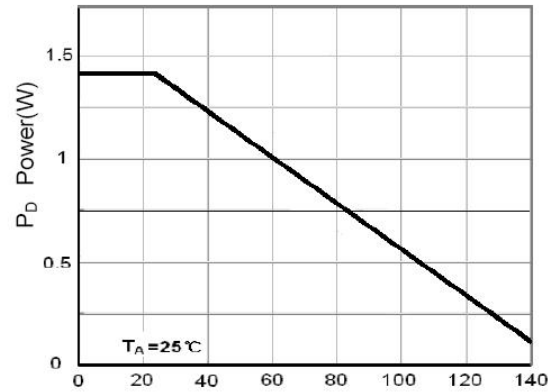

Figure 8 Power Dissipation

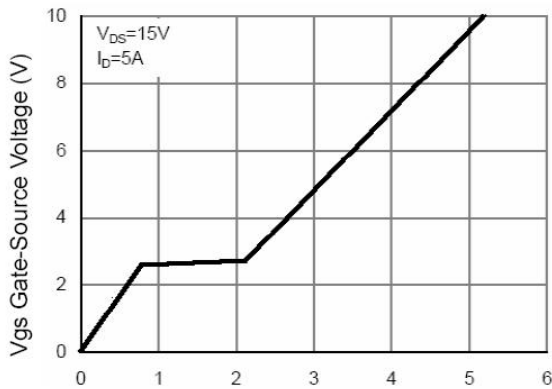

Figure 9 Gate Charge

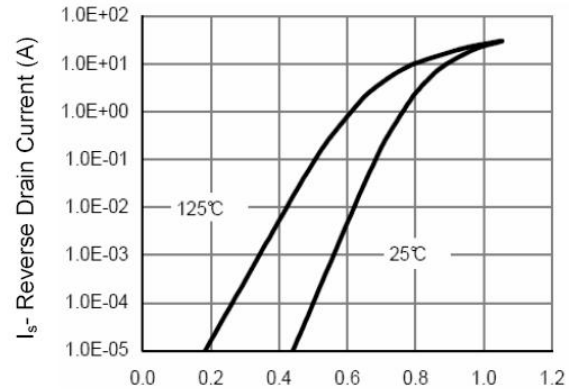

Figure 10 Source-Drain Diode Forward

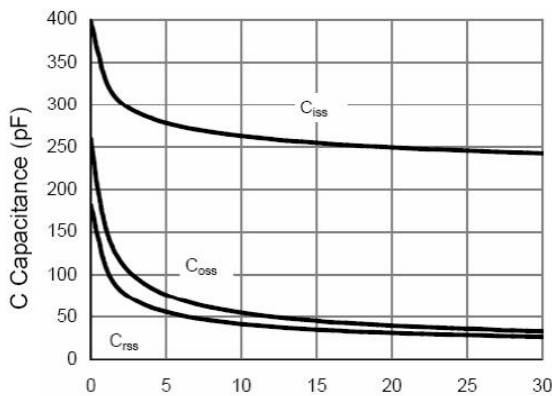

Figure 11 Capacitance vs Vds

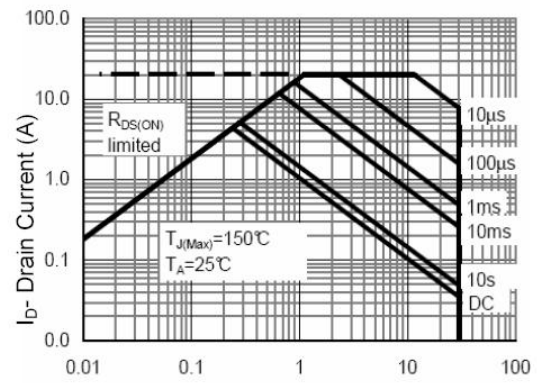

Figure 12 Safe Operation Area



GL3404

GL Silicon N-Channel Power MOSFET

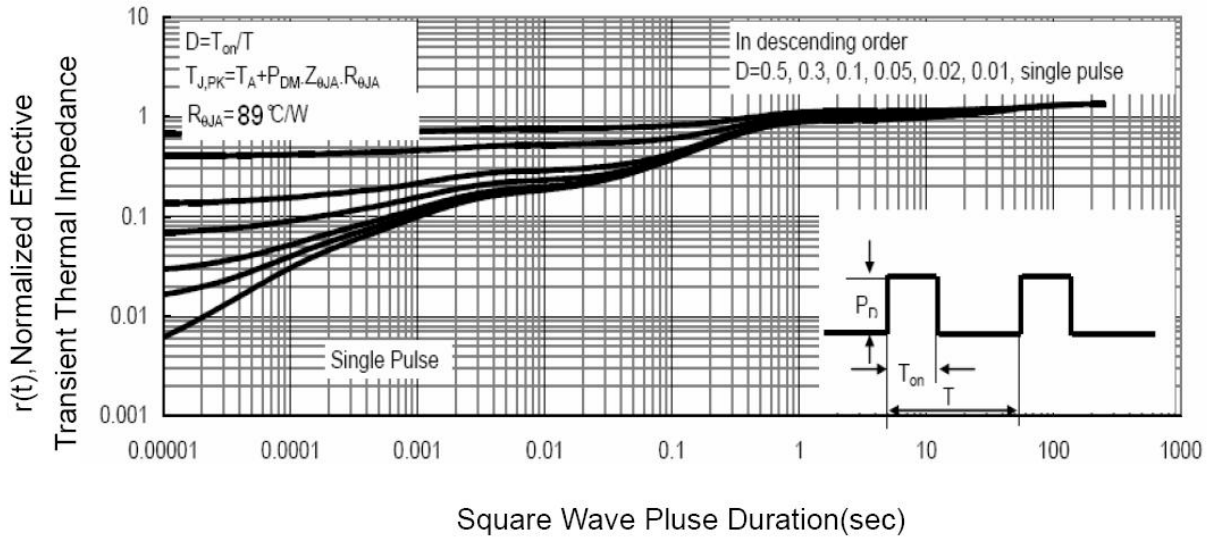

Figure 13 Normalized Maximum Transient Thermal Impedance